

# Instructivo para montaje de puente JSS-06-08-10/35

## Instructions for mounting the JSS-06-08-10/35 jumper

Este puente facilita la conexión del borne WSS-06 con los bornes WSS-08 y WSS-10, asegurando la interconexión adecuada de los componentes.

*This jumper facilitates the connection of the WSS-06 terminal block with the WSS-08 and WSS-10 terminals blocks, ensuring the proper interconnection of the components.*

### Conexión WSS-06 a WSS-08

#### Connection of WSS-06 to WSS-08

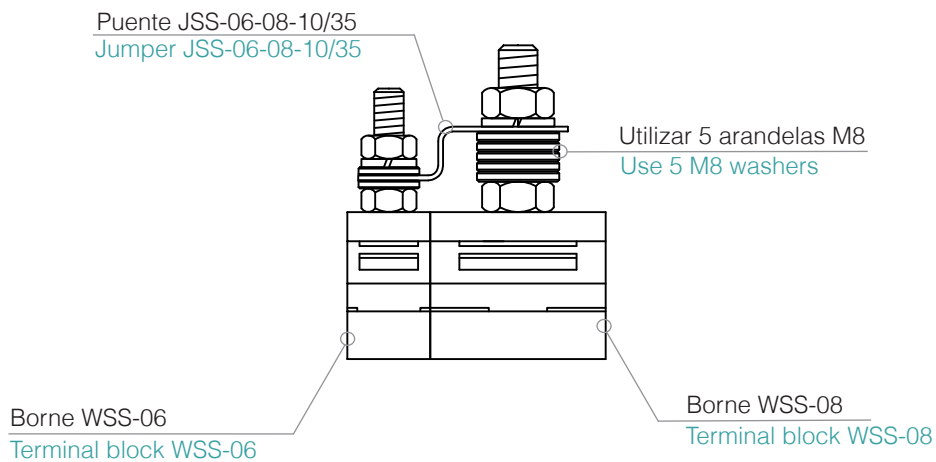

### Conexión de WSS-06 a WSS-10

#### Connection of WSS-06 to WSS-10

