

# Instrucciones para el conexionado y extracción de bornes - ZCTP

## Instructions for wire connection and removal of terminal blocks

Para el correcto conexionado entre los terminales y el borne utilice la arandela apropiada que se indica en la tabla a continuación.

*In order to properly connect the terminals and terminal block, please use the correct washer indicated in the table below.*

	Sección del conductor <i>Cross-section of conductor</i>	Ø externo de arandela <i>Outer Ø of washer</i>	Destornillador sugerido para extraer el borne <i>Suggested screwdriver to remove the terminal block</i>
ZCTP-150/35	35	12	DES-06
ZCTP-250/35	120	25	DES-06
ZCTP-250/35	95	25	DES-06
ZCTP-250/35	70	25	DES-06
ZCTP-250/35	50	20,7	DES-06
ZCTP-600/35	240	40	DES-06
ZCTP-600/35	185	30	DES-06
ZCTP-600/35	150	30	DES-06

Para realizar la extracción utilizar dos destornilladores planos con ambas manos.

*Use two slot tip screwdrivers with both hands to remove the terminal block.*

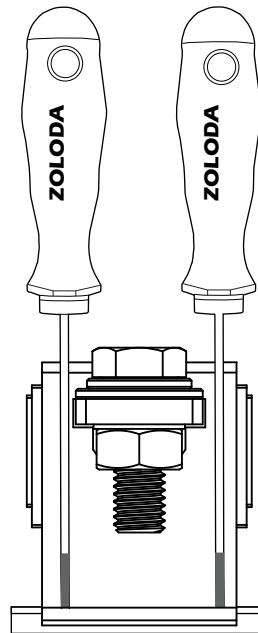
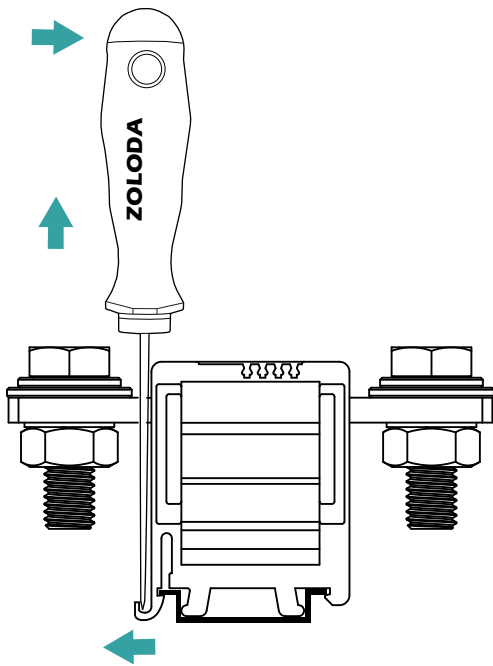

Puntos de aplicación  
Correct opening position

